

## SWING CHECK VALVES—Class 1500#, 2500#

Size range: 2" to 24"

Size range: 2" to 20"

Class 1500# Fig NO. 299(RF/RTJ)  
299 1/2 (BW)

**DIMENSIONS AND WEIGHTS**

Size inch	d	A		Weight(kg)	
		RF & BW	B	RF & BW	BW
2"	47	368	241	69	49
3"	70	470	280	140	111
4"	92	546	340	232	185
6"	136	705	424	490	375
8"	178	832	475	990	803
10"	222	991	559	1490	1250
12"	263	1130	660	1970	1625
14"	289	1257	780	2860	2489
16"	330	1384	843	4050	3526
18"	371	1537	914	5600	5085
20"	416	1664	1030	7000	6258

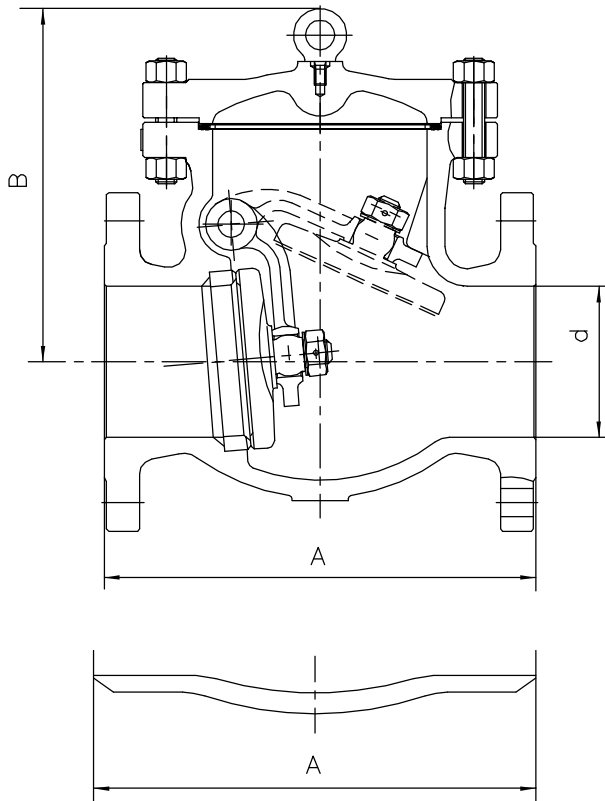

Class 2500# Fig NO. 267(RF/RTJ)  
267 1/2 (BW)

**DIMENSIONS AND WEIGHTS**

Size inch	d	A		Weight(kg)	
		RF & BW	B	RF & BW	BW
2"	38	451	302	120	101
3"	57	578	363	210	168
4"	73	673	381	345	278
6"	111	914	432	740	654
8"	146	1022	605	1230	1105
10"	184	1270	800	2100	1796
12"	219	1422	1100	3500	3125

STANDARDS:	
Design	ANSI B16.34&BS 1868
Test	API 598
Face to Face Dimensions	ANSI B16.10
End Flange Dimensions	ANSI B16.5
Butt-Weld Ends	ANSI B16.25

Other Sizes: On request  
RF: Flanged      BW: Butt Weld

**AVAILABLE OPTIONS:**

STRUCTURE	End, Connection: Flange Raised Face, Butt Weld, RTJ...
	Seat Rings: Threaded (Renewable), Welded
*MATERIAL	Body: WCB, WC1, WC6, WC9, LCB, LCC, LC3, C5, C12, CF8, CF8M, CF3, CF3M, CF8C...
	Trims: 13%Cr, 304, 304L, 316, 316L, 321, 347, F-51, Monel...
Accessories	Hydraulic Damper, Counter Weight (Lever + Weight)

\*Please refer to page of "Build Material"